

# LoRa RFT-Tracker 16

GPS/LoRa Tracker

Rev 3

## GENERAL DESCRIPTION

### Product general description:

The RFT-Tracker 16 is a compact and stand-alone low power module with GPS / LoRa functions, designed to be installed on vehicles or assets in order to geolocalize them.



### Main key features:



LoraWan Class A connectivity



GPS and TDOA Geo-location



Very low power design



Accelerometer



Motionless detection condition for extended battery life



17Ah Lithium- Thionyl Chloride cell Embedded

### Optional key features:



ILS (magnetic On/Off switch)



BLE or NFC connectivity to configure and activate/deactivate the device



"Discover" feature, based on RF-Track LoRa private protocol, to identify where is located the tracker-16 (without using the geolocation reports by LoRaWAN)



Transmission of the 3 "last positions" tracking history



## RFT-Tracker 16

GPS/LoRa Tracker Rev 3

### Special embedded functions:

- Stop and go detection report
- "Mobility rate" meter
- Downlink commands to set up the device

Special care has been taken to lower current consumption, powering on GPS and LoRa transceiver only when needed. The accelerometer can be used to detect motionless condition to deactivate the GPS in order to further extend battery life. Using LoRa module, geo-location data are transmitted to a public or private LoRaWAN network and can be used by your customer application.

### ESTIMATED LIFETIME

GPS Geolocation Only (without using "Discover" and BLE features) :

#### Tracker in motion 8 hours per day

- GPS fix every 2 hrs not moving and every 10mn when moving -> 2.5yrs
- GPS fix every 4 hrs not moving and every 20mn when moving -> 5.0yrs

#### Tracker in motion 1 hour per day

- GPS fix every 2 hrs not moving and every 10mn when moving -> 7.0yrs
- GPS fix every 4 hrs not moving and every 20mn when moving -> 10.0yrs



# RFT-Tracker 16

GPS/LoRa Tracker Rev 3



GPS Geolocation only on stop and go detection when moving, TDOA otherwise (without using "Discover" and BLE features) :

Tracker in motion 8 hours per day

**Moving:** GPS location every stop and go (3 stop and 3 start /day) TDOA location every 10mn

**Not Moving:** GPS location every 24 hrs => Lifetime = 12yrs

Temperature range [-20°C, +55°C]

## FUNCTIONALITIES

**Normal mode:** transmit a position (GPS or TDOA) at fixed periodic rate, even if the tracker detects motionless.

**Motion detection mode:** transmit a GPS or TDOA position at a shorter periodic rate if the tracker is moving. Motion detection is performed using embedded accelerometer with algorithms.

**Upload rate configuration:** Periodic rates of the two previous modes can be changed by a downlink command, configured from your customer application.

**Stop and go detection:** Based on the embedded accelerometer, the tracker sends the location where it has been detected.



## RFT-Tracker 16

GPS/LoRa Tracker Rev 3

### MECHANICAL CHARACTERISTICS

IP65 compliant enclosure

**Dimensions** : 110 x 82 x 55 mm

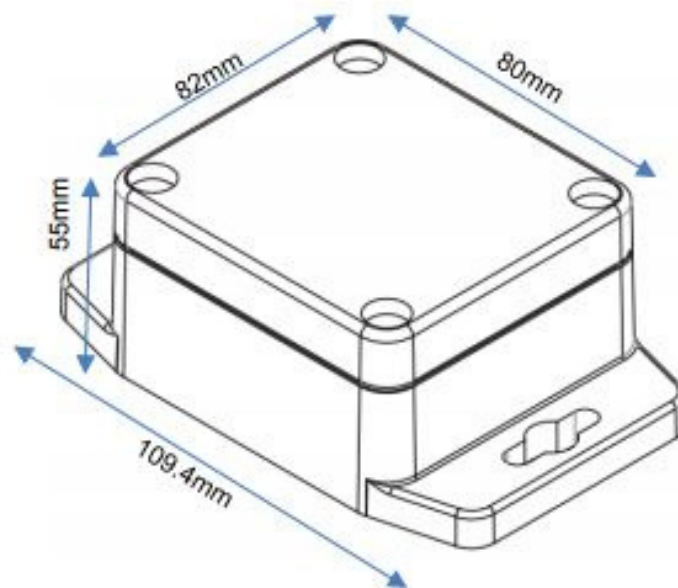

### APPLICATIONS

- Vehicles fleet and asset geo-location
- Remote diagnosis and maintenance for industrial machines (movements, vibrations, use rates)
- Theft detection

### CUSTOMISATION ON DEMAND

- PT100 temperature measure
- External sensors interfaces
- External power supply